



VARTA BLACK dynamic

Vehicle Key Benefits



Разработени в съответствие с най-високите стандарти в Германия



Патентована PowerFrame® решетка за надеждна стартова мощност, бързо зареждане и устойчивост на корозия



Изпълнява изискванията на OE като съответстваща резервна част

For more information visit varta-automotive.com

ORDER INFORMATION

European Type No. (ETN):	590122072
Article Number:	5901220723122
Short Code:	F6
Barcode:	4016987119457
UK Code:	017
Packaging Unit:	1
Quantity per Pallet:	36

TECHNICAL INFORMATION

Voltage [V]:	12	Base Hold-down:	B13
Battery Capacity [Ah]:	90	Layout:	0
CCA, EN [A]:	720	Terminal Types:	1
Length [mm]:	353	Case Size:	H8/LN5
Width [mm]:	175	Weight filled (kg):	20,78
Height [mm]:	190		

DRAWINGS

B13

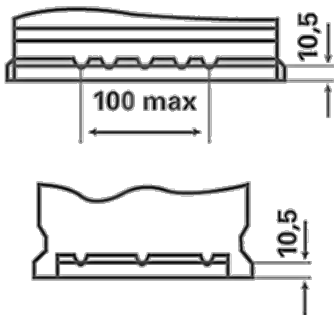

0

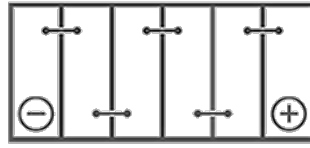

1

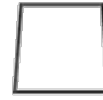

ø 19,5
H 18

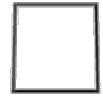

ø 17,9
H 18



pos.

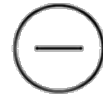

neg.