



VARTA BLUE dynamic EFB

Vehicle Key Benefits



Подходящ за базово ниво Старт-Стоп системи



Разработени в съответствие с най-високите стандарти в Германия



Патентована PowerFrame® решетка за надеждна стартова мощност, бързо зареждане и устойчивост на корозия

For more information visit varta-automotive.com

ORDER INFORMATION

European Type No. (ETN):	595500085
Article Number:	595500085D842
Short Code:	N95
Barcode:	4016987152331
UK Code:	019EFB
Packaging Unit:	1
Quantity per Pallet:	36

TECHNICAL INFORMATION

Voltage [V]:	12	Base Hold-down:	B13
Battery Capacity [Ah]:	95	Layout:	0
CCA, EN [A]:	850	Terminal Types:	1
Length [mm]:	353	Case Size:	H8/LN5
Width [mm]:	175	Weight filled (kg):	24,49
Height [mm]:	190		

DRAWINGS

B13

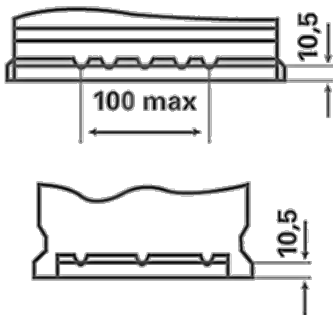

0



1

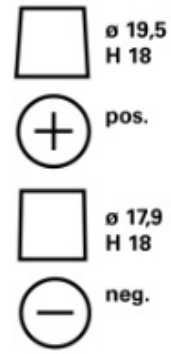

3

