



VARTA SILVER dynamic

Køretøjets nøglefordel



Designet til at opfylde de højeste tyske standarder.



Patenteret PowerFrame® giver til pålidelig startstrøm, hurtig opladning og korrosionsmodstand.



Tåler betydelig dybdeafledning

For mere information besøg varta-automotive.com

BESTILLINGSINFORMATION

ETN:	563401061
Artikel nummer:	5634010613162
Kort kode:	D39
Stregkode:	4016987119761
UK kode:	077
Emballageenhed:	1
Antal pr. palle:	63

TEKNISKE INFORMATIONER

Spænding [V]:	12	Base Hold-down:	B13
Batterikapacitet [Ah]:	63	Layout:	1
Koldstartsstrøm [A]:	610	Poltype:	1
Længde [mm]:	242	Kabinetstørrelse:	H5R/LN2R
Bredde [mm]:	175	Vægt (tom):	14,78
Højde [mm]:	190		

B13

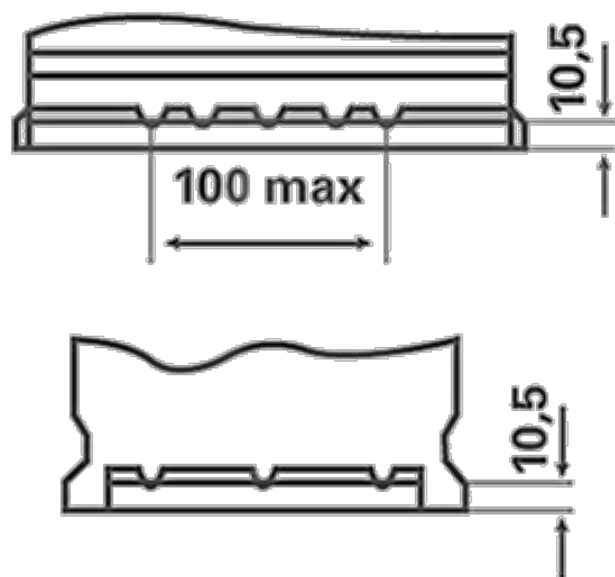

1



ø 19,5
H 18



pos.



ø 17,9
H 18



neg.

3



ø 14,7
H 18



pos.



ø 13,1
H 18

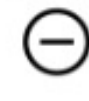

neg.