



VARTA BLACK dynamic

Fordelen med nøkkelen



Konstruert etter de høyeste tyske standarder.



Patentert PowerFrame® gitter for pålitelig startkraft, rask oppladning og korrosjonsbestandighet.



Oppfyller kravene fra originalutstyrproducenter som kompatibel reservedel

For mer informasjon besøk varta-automotive.com

OBESTILLINGSINFORMASJON

ETN:	553401050
Artikkelnummer:	5534010503122
Kortnummer:	C11
Strekkode:	4016987143612
UK kode:	065
Emballasje:	1
Antall på pall:	63

TEKNISK INFORMASJON

Spenning [V]:	12	Base Hold-down:	B13
Batterikapasitet [Ah]:	53	Oppsett:	0
Kaldstartstrøm EN [A]:	500	Terminal typer:	1
Lengde [mm]:	242	Størrelse på hus:	T5/LNB2
Bredde [mm]:	175	Vekt [tomt]:	13,27
Høyde [mm]:	175		

B13

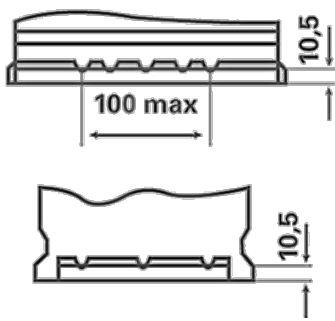

0

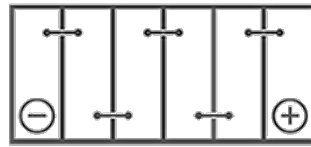

1

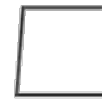

ø 19,5
H 18



ø 17,9
H 18



pos.

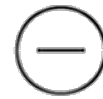

neg.