



## VARTA SILVER dynamic

### Køretøjets nøglefordel



Designet til at opfylde de højeste tyske standarder.



Patenteret PowerFrame® giver til pålidelig startstrøm, hurtig opladning og korrosionsmodstand.



Tåler betydelig dybdeafledning

For mere information besøg [varta-automotive.com](http://varta-automotive.com)

### BESTILLINGSINFORMATION

ETN:	552401052
Artikel nummer:	5524010523162
Kort kode:	C6
Stregkode:	4016987119747
UK kode:	063
Emballageenhed:	1
Antal pr. palle:	72

### TEKNISKE INFORMATIONER

Spænding [V]:	12	Base Hold-down:	B13
Batterikapacitet [Ah]:	52	Layout:	0
Koldstartsstrøm [A]:	520	Poltype:	1
Længde [mm]:	207	Kabinetstørrelse:	T4/LBN1
Bredde [mm]:	175	Vægt (tom):	11,97
Højde [mm]:	175		

**B13**

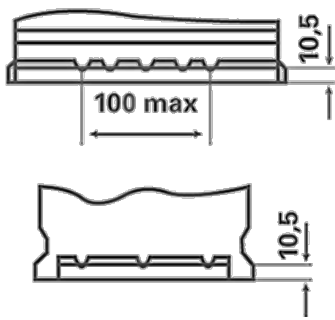

**0**

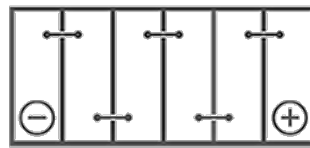

**1**

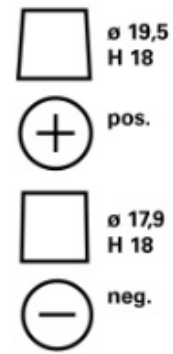

**3**

