



## VARTA SILVER dynamic

### Køretøjets nøglefordel



Designet til at opfylde de højeste tyske standarder.



Patenteret PowerFrame® gitter til pålidelig startstrøm, hurtig opladning og korrosionsmodstand.



Tåler betydelig dybdeafledning

For mere information besøg [varta-automotive.com](http://varta-automotive.com)

### BESTILLINGSINFORMATION

ETN:	610402092
Artikel nummer:	6104020923162
Kort kode:	I1
Stregkode:	4016987119587
UK kode:	020
Emballageenhed:	1
Antal pr. palle:	36

### TEKNISKE INFORMATIONER

Spænding [V]:	12	Base Hold-down:	B13
Batterikapacitet [Ah]:	110	Layout:	0
Koldstartsstrøm [A]:	920	Poltype:	1
Længde [mm]:	393	Kabinetstørrelse:	H9/LN6
Bredde [mm]:	175	Vægt (tom):	24,48
Højde [mm]:	190		

**B13**

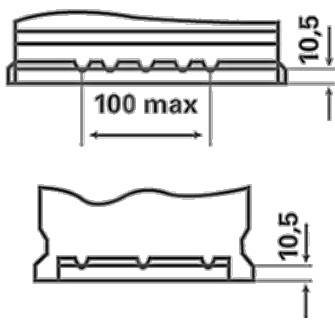

**0**

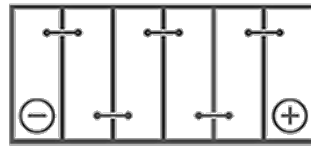

**1**

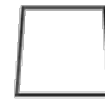

ø 19,5  
H 18

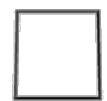

ø 17,9  
H 18



pos.

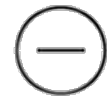

neg.