



KØRETØJETS NØGLEFORDEL

Udviklet i Tyskland

VARTA-batterier er udviklet i Tyskland og leverer præcisionsydelse og varig pålidelighed

Patenteret PowerFrame[®]

Patenteret PowerFrame[®] giver til pålidelig startstrøm, hurtig opladning og korrosionsmodstand.

Originale reservedele

Opfylder alle erhvervskøretøjsproducentens oprindelige kriterier

PROMOTIVE SHD

670104100A732

TEKNISKE INFORMATIONER

Batterikapacitet:	170 Ah	Koldstartsstrøm:	1000 A
Spænding:	12 V	Dimensioner (L/B/H):	513/223/223
Kabinetstørrelse:	B	Kort kode:	M9
UK kode:	620HD	ETN:	670104100
Vægt (tom):	44,200 kg	Bund fastholdelse:	B03

TEGNINGER

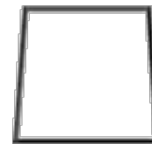
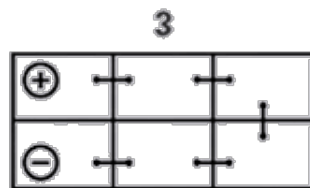
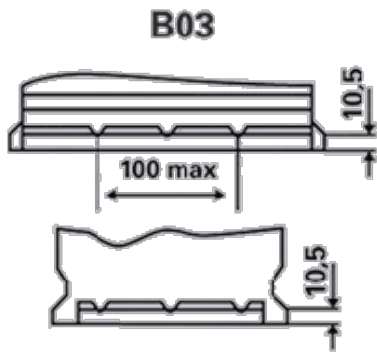

ø 19,5
H 18



pos.



ø 17,9
H 18



neg.