

DYNAMIC AGM

570901076K262



Vehicles with Start-Stop technology and electric vehicles with advanced energy needs.

The VARTA Dynamic AGM delivers ultimate performance, boasting three times the cycle life of conventional batteries. It's the best performance for vehicles with highest energy demands, including those with Start-Stop functionality or the latest electric vehicles.

VEHICLE KEY BENEFITS



xEV ready

Ensuring safety and reliability for all current and future vehicle demands.



Start-Stop

Best start-stop performance for maximum fuel economy – as the start-stop-system can be operated as often as possible.



3x cycle life

3x cycle life compared with a conventional battery.



Highest energy demands

Best performance for high-energy Start-Stop and multiple types of electric vehicles.



Original equipment spare part

Meets all OE criteria from the vehicle manufacturer.



Made in Germany

High quality, best-in-class manufacturing.



Maintenance-free

Maintenance-free battery designed to deliver dependable performance for your vehicle.

DYNAMIC AGM

570901076K262

TECHNICAL DATA

Capacity:	70 Ah	CCA:	760 A
Voltage:	12 V	Dimensions (L/W/H):	278/175/190
Case Size:	H6/L3	Short Code:	A7
UK-Code:	096AGM	ETN:	570901076
Weight filled:	20,4 kg	Base Hold-down:	B13
Layout:	0	Terminal Type:	1

DRAWINGS

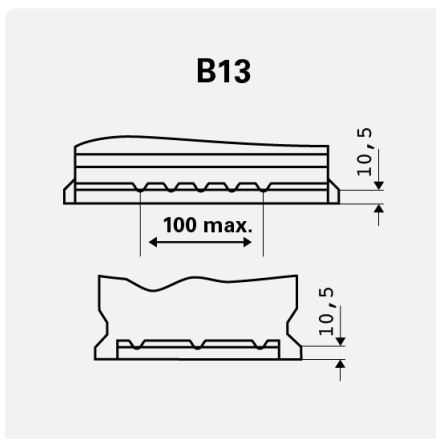

Base Hold-down

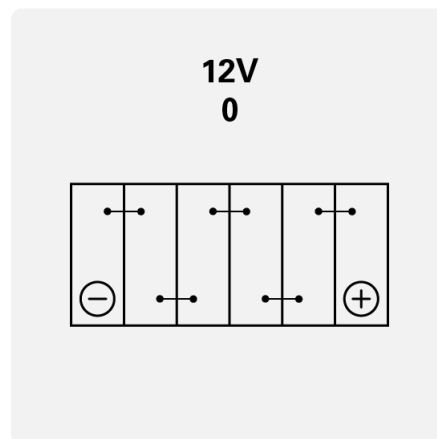

Layout

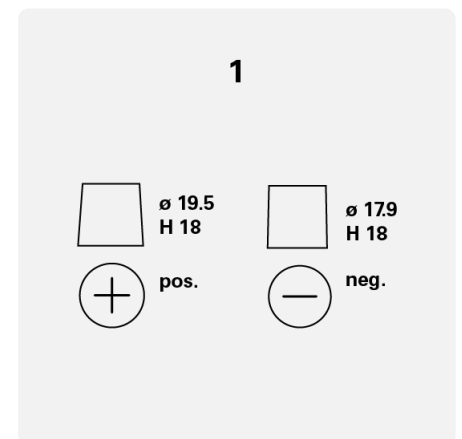

Terminal Type