



For urban distribution, agricultural and construction applications.

The VARTA ProMotive SLI is built to deliver the confident starting power to rely on. Engineered as an Original Spare Part, it ensures the vehicle is always ready to work, day in and day out. VARTA batteries meet all the standards of OE manufacturers. Engineered in Germany, VARTA batteries deliver precision performance and lasting reliability.

VEHICLE KEY BENEFITS



Reliable power

Reliable power to minimize downtime.



Standard vibration resistance

For continuous multistart applications with basic vibration requirement.



Original equipment spare part

Meets all OE criteria from the vehicle manufacturer.



Engineered in Germany

Engineered with precision and expertise in Germany.



Made in Europe

Produced to the highest European standards ensuring best in class manufacturing quality.

PROMOTIVE SLI

670104100K182

TECHNICAL DATA

Capacity:	170 Ah	CCA:	1000 A
Voltage:	12 V	Dimensions (L/W/H):	513/223/223
Case Size:	B	Short Code:	M9
UK-Code:	620SHD	ETN:	670104100
Weight filled:	44,20 kg	Base Hold-down:	B03
Layout:	3	Terminal Type:	1

DRAWINGS

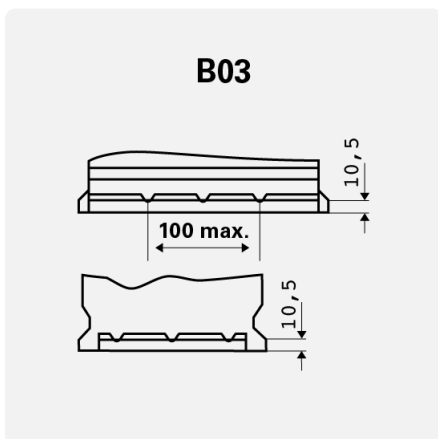

Base Hold-down

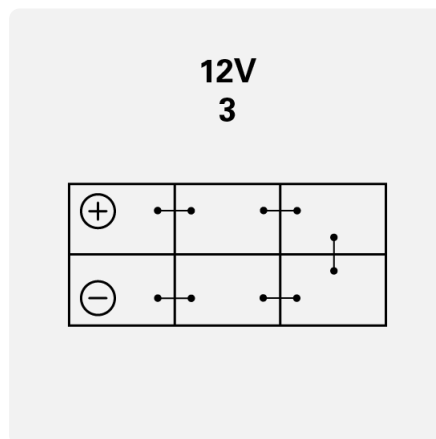

Layout



Terminal Type