







PRINCIPAIS BENEFÍCIOS DA BATERIA

	Start Stop	Preparada para sistemas start-stop básicos.
	Engenharia alemã	Desenvolvida segundo os mais elevados padrões alemães.
	PowerFrame[®] patenteada	Para uma potência de arranque fiável, carregamento rápido e resistência à corrosão.
	Critérios originais	Bateria fabricada de acordo com os padrões e especificações do fabricante original (OE)

BLUE DYNAMIC EFB

560500064D842

INFORMAÇÕES TÉCNICAS

Capacidade da bateria:	60 Ah	Corrente de ensaio a frio EN:	640 A
Tensão:	12 V	Dimensões (C/L/A):	242/175/190
Tamanho da caixa:	H5/LN2	Short Code:	N60
UK-Code:	027EFB	ETN:	560500064
Peso (sem líquido):	16,93 kg	Retenção da base:	B13

DESENHOS

B13

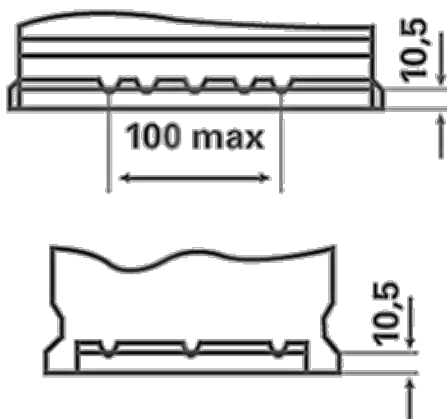

0

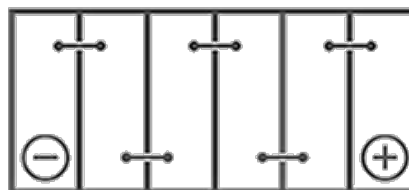

1



3

