







PRINCIPAIS BENEFÍCIOS DA BATERIA

	Start Stop	Preparada para sistemas start-stop básicos.
	Engenharia alemã	Desenvolvida segundo os mais elevados padrões alemães.
	PowerFrame[®] patenteada	Para uma potência de arranque fiável, carregamento rápido e resistência à corrosão.
	Critérios originais	Bateria fabricada de acordo com os padrões e especificações do fabricante original (OE)

BLUE DYNAMIC EFB

570500076D842

INFORMAÇÕES TÉCNICAS

Capacidade da bateria:	70 Ah	Corrente de ensaio a frio EN:	760 A
Tensão:	12 V	Dimensões (C/L/A):	278/175/190
Tamanho da caixa:	H6/LN3	Short Code:	N70
UK-Code:	096EFB	ETN:	570500076
Peso (sem líquido):	19,53 kg	Retenção da base:	B13

DESENHOS

B13

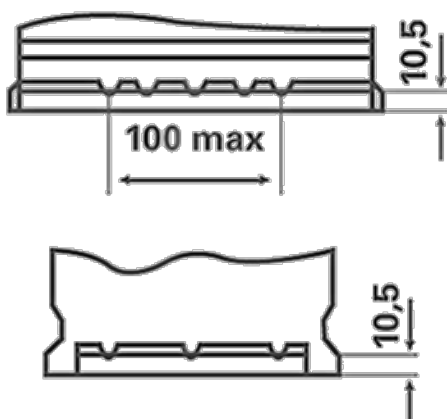

0

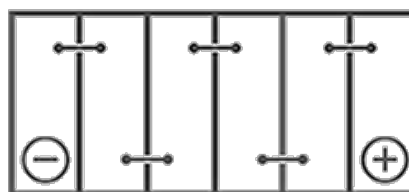

1



3

