



VARTA BLUE dynamic EFB

Fordons nyckelfördel



Redo att användas i start/stopp-system på ingångsnivå.



Utvecklat enligt högsta tyska standard.



Patenterat PowerFrame®-galler för pålitlig startkraft, snabbare återuppladdning och hög korrosionstålighet.



Hög djupurladdningsförmåga

För mer information besök varta-automotive.com

ORDERINFORMATION

ETN:	575500073
Artikelnummer:	575500073D842
Kortnummer:	E46
Streckkod:	4016987144572
UK kod:	110EFB
Förpackningsenhet:	1
Palett:	48

TEKNISK INFORMATION

Volttal [V]:	12	Base Hold-down:	B13
Batterikapacitet [Ah]:	75	Layout:	0
Kallstartström CCA EN [A]:	730	Terminaltyper:	1
Längd [mm]:	315	Höljets storlek:	T7/LBN4
Bredd [mm]:	175	Vikt fyllt och laddat:	21,19
Höjd [mm]:	175		

B13

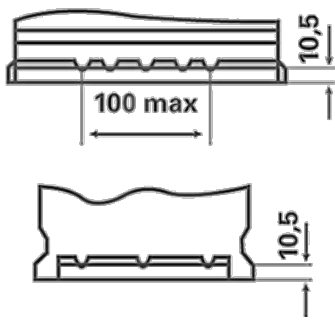

0

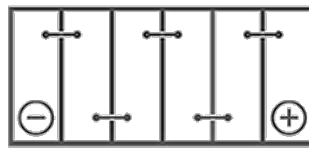

1



3

